

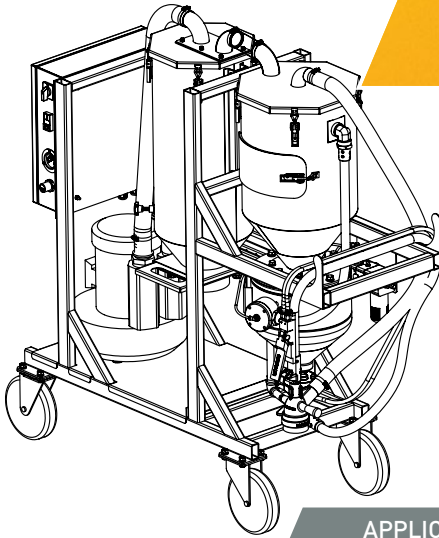

CATALOGUE # 1.0

**BRS-SERIES PORTABLE DUST-FREE
BLAST AND RECOVERY SYSTEMS**



Blast Recovery System BRS-2

FUNCTIONAL FEATURES

- Blast vessel capacity: 13l
- Manual filter cleaning
- Electrically driven vacuum: 2.2kW
- Used blast media: aluminum oxide (recommended), steel grit max. G40/G50
- Average production capacity (per hour): 3 m² flat surface or 40 mm weld seams
- Adjustable blasting pressure: 3-10 bar
- Suction hose length: max. 10m (scope of delivery 5m)
- Average blast pattern: Ø40-50mm

APPLICATION

Closed-circuit abrasive blast cleaning, ideal for indoor blasting where dust and abrasive contaminants should be avoided, for the blasting of welding seams and for spot repairs.

The BRS-5 Blast Recovery System is an electrically operated, pressure-feed closed-circuit blast machine, which can be used where open-air blasting is prohibited, or is not possible or practical. Blasting and simultaneous media recovery are initiated by pulling the DMH handle. Keeping the blast area clean allows the operator to blast without the need to encapsulate the area or wear respiratory protective equipment.

STANDARD DELIVERY

BRS-2 systems are mounted on the portable frame and include a cyclone dust separator and media reclaimer, 13l blast vessel, dust collector with a cartridge filter and manual filter cleaning, fully pneumatic remote control and blast pressure control, compressed air moisture filter, 5m blast and vacuum hoses, vacuum head BSH-40 with three brushes, NTC-5.0 blast nozzle, DMH handle.

Order code	Model	Description
10300003	BRS-2	Blast Recovery System, 2.2kW power, with 5m blast and vacuum hoses, complete



Blast Recovery System BRS-5

FUNCTIONAL FEATURES

- Blast vessel capacity: 50l
- Automatic pulse jet filter cleaning
- Electrically driven vacuum: 5.5kW
- Used blast media: aluminum oxide (recommended), steel grit max. G18/G25
- Average production capacity (per hour):
6 m² flat surface or 80 m weld seams
- Adjustable blasting pressure: 3-10 bar
- Suction hose length: max. 15m (scope of delivery 5m)
- Average blast pattern: Ø60-75mm

APPLICATION

Closed-circuit abrasive blast cleaning, ideal for indoor blasting where dust and abrasive contaminants should be avoided, for the blasting of welding seams and for spot repairs.

The BRS-5 Blast Recovery System is an electrically operated, pressure-feed closed-circuit blast machine, which can be used where open-air blasting is prohibited, or is not possible or practical. Blasting and simultaneous media recovery are initiated by pulling the DMH handle. Keeping the blast area clean allows the operator to blast without the need to encapsulate the area or wear respiratory protective equipment.

STANDARD DELIVERY

BRS-5 systems are mounted on the portable frame and include a cyclone dust separator and media reclaimer, 50l blast vessel, dust collector with a cartridge filter and automatic pulse jet filter cleaning, fully pneumatic remote control and blast pressure control, compressed air moisture filter, 5m blast and vacuum hoses, vacuum head BSH-50 with three brushes, MTC-6.5 blast nozzle, DMH handle.

Order code	Model	Description
10300002	BRS-5	Blast Recovery System, 5.5kW power, with 5m blast and vacuum hoses, complete

BSH Blast and Vacuum Heads



A dust-free abrasive blast system includes a combined blast and vacuum head BSH, fitted with a nylon-bristle brush that presses against the blast surface. The BSH blast and vacuum head assembly comprises a blast nozzle and a vacuum hose, which evacuates dust and the rebounding abrasive following its contact with the blast surface. This BSH blast and vacuum head contains the abrasive and keeps the surrounding area clean.

BSH-40 BLAST AND VACUUM HEAD

For suction hose I.D.=40mm and Contracor NTC blast nozzle.



BSH-50 BLAST AND VACUUM HEAD

For suction hose I.D.=50mm and Contracor MTC blast nozzle.



Order code	Model	Description
22170200	BSH-40	Blast-Suction-Head, with three brushes, without blast nozzle
22160004		Brush for Blast-Suction-Head BSH-40, flat
22160005		Brush for Blast-Suction-Head BSH-40, edge
22160006		Brush for Blast-Suction-Head BSH-40, pipe

Order code	Model	Description
22170100	BSH-50	Blast-Suction-Head, with three brushes, without blast nozzle
22160001		Brush for Blast-Suction-Head BSH-50, flat
22160002		Brush for Blast-Suction-Head BSH-50, edge
22160003		Brush for Blast-Suction-Head BSH-50, pipe

This Catalogue is valid from 01.02.2024

All previous catalogues lose their validity with the publication of the new catalogue. Technical characteristics, specifications and details published in this catalogue are subject to change without notice.

Comprag GmbH.

Copyright © Comprag ®. All rights reserved.

COMPRAG GMBH

www.comprag.com